



#### Before you Start

#### Wall construction

The wall referred to in these instructions is ex 100mm x 50mm wooden framework. In reality this may mean a 94mm x 47mm or 90mm x 45mm wooden framework. Although not shown, the unit may also be fitted into other types of wall materials (steel, concrete, brick, etc.).

For concrete or masonry walls, fix a 100mm x 50mm timber jack stud into the opening on each side. Fix these in place with  $\phi 10\text{mm}$  x 98mm long countersunk masonry anchors at 400mm centres.

The lintel should be straight and level.

The jack studs should be straight and plumb to the lintel.

#### Lintel/trimmer sizes.

CS Cavity Sliders are non-loadbearing. The lintel (or trimmer, ceiling joist or other structural component) directly above the track must span the full trim size opening width.

Timber lintels sized from NZS3604 (NZ) / AS1684 (AU) are acceptable if the weight of the doors is less than 75kg/m width of door. If heavier, specific design is required. Please consult your engineer.

#### Trim size (hole in the wall framing) (All units including SofStop):

**Height:** door leaf height + 95mm

**Width:** (door width x 4) + 10mm

#### Standard under door clearance.

With the unit sitting hard on top of the concrete or timber floor, the clearance under the door leaf ranges between 25 - 32mm (adjustable). The majority of this clearance is taken up by the floor covering (carpet, tiles etc.).

#### Modified under door clearance.

If you require **more** than 32mm clearance under the door: pack the cavity unit off the floor by the amount you need. If you need **less** than 25mm clearance (e.g. polished timber floors) there are three options:

a) CS can supply seals which fit to the bottom of the door.

b)\* A door up to 15mm taller can be fitted.

c)\* The whole unit can be made up to 15mm shorter.

\*b & c must be **pre-ordered**.

#### Contamination of the top track.

Never drill, nail or screw through the centre section of the track. The track running surface must be clean and free of any contamination or damage, e.g. paint or dust. The wheels on the carriage should not be chipped, dented or have swarf embedded in the tyre. **Take extra care with the carriages to avoid any damage during the installation process.**

#### Fixing cavity slider to the floor

Installing the cavity slider 100% plumb and level will **NOT** guarantee a correctly sliding door.

If the wall, lintel, floor and door are not all plumb, level and straight, the door may slide incorrectly into the pocket.

For this reason, the skirting block fixing (at the base of the pocket frame behind the split jambs) should only be secured once you have ensured the doors are running parallel to the cavity pockets.

#### Preparation

#### 1. Remove packaging and check components.

Position the cavity units so the aluminium back studs are parallel with the floor and remove the transport support cleats (if fitted) from the bottom plate assemblies. Check for any transportation damage.

If anything looks damaged or out of specification or you are unsure, contact CS **before** beginning your install.

#### 2. Fit the tracks (if not already fitted).

Check inside the tracks and clean out all dust and debris.

Remove all temporary frame packers marked "remove".

Slide the track into each unit and fix to the aluminium split jambs and back stud.

Make sure that the track holes line up with the split jamb screw tubes.

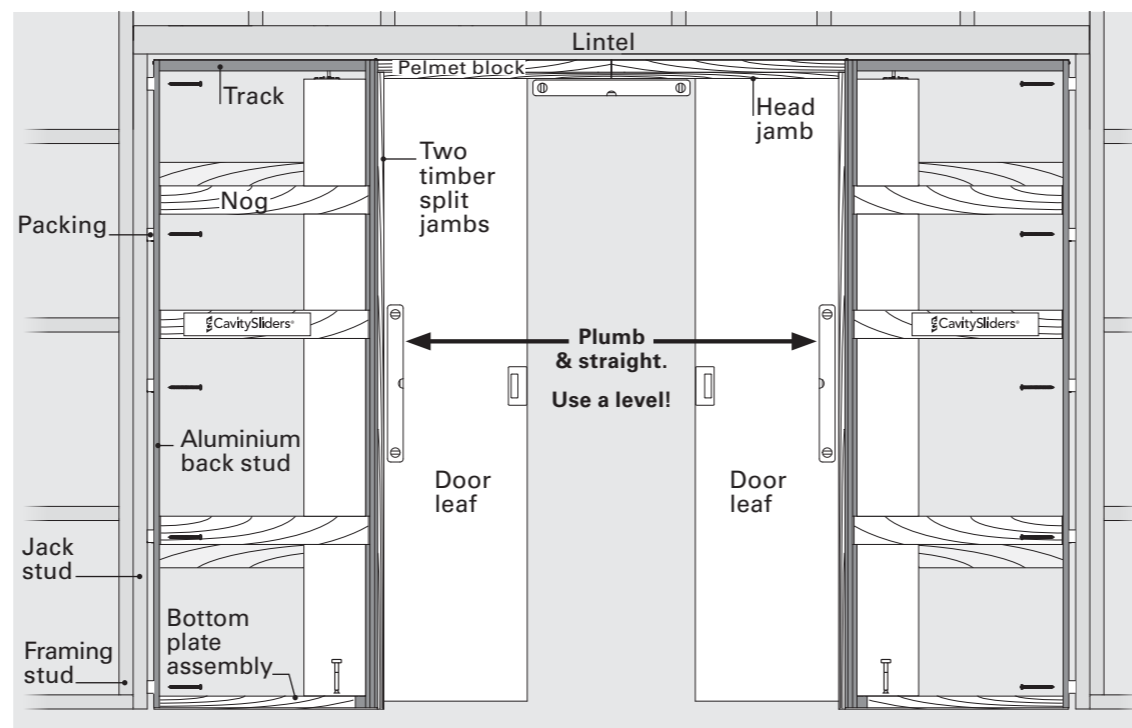
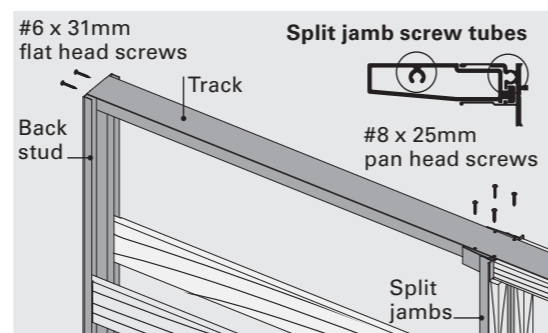

#### 3. Prepare doors (if not already fitted).

a) At the bottom of the doors, cut a groove to the dimension and tolerance shown below.

Make it central to the door thickness and absolutely straight.

b) Drill mounting plate holes to the correct size and depth as marked.

c) Fix both mounting plates to the door.

The larger of the two mounting plates (the one with the black plastic stop) fits closest to the leading edge of the door. Make sure the black plastic stop is facing the leading edge of the door.

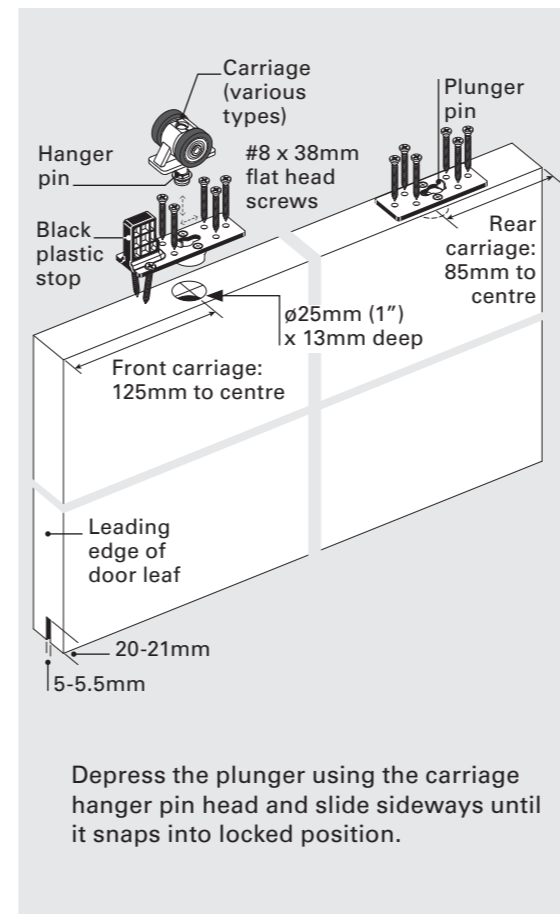

#### 4. Fit doors (if not already fitted).

Slide door and carriages into track (A, B or C).

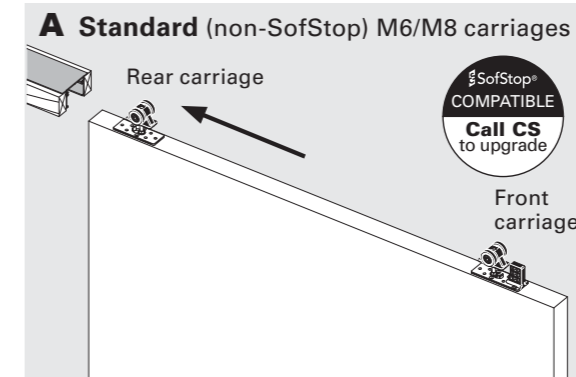

#### B SofStop® Single (Soft Close)

Attach cassette to front carriage with M5 pan head machine screw. Tighten with #2 Phillips screwdriver.

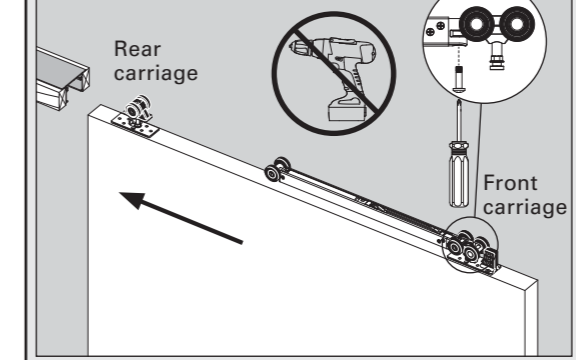

#### C SofStop® Twin (Soft Open & Close)

**DO NOT LINE THE POCKET UNTIL THE SOFSTOP MECHANISM HAS BEEN INSTALLED AND TESTED.**

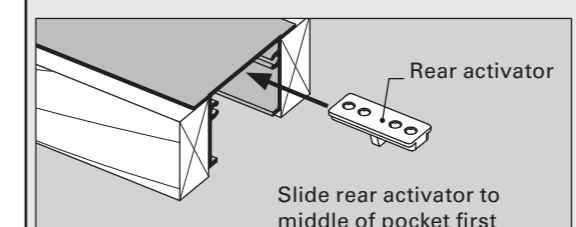

Attach cassette to front carriage with M5 pan head machine screw. Tighten with #2 Phillips screwdriver.

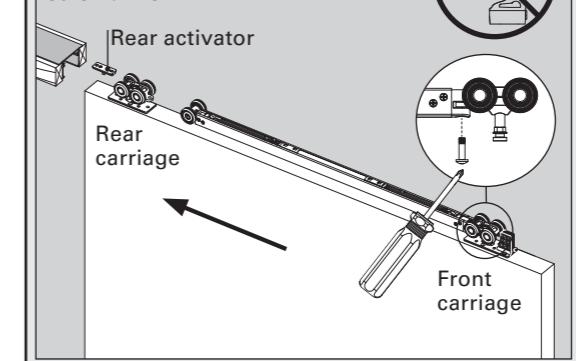

#### Installation

#### 5. Place units into framed opening.

Connect the tracks together with the alignment pins provided. These are already fitted into the track screw tubes on one of the units.

Plumb up the two split jambs. **Use a level!**

#### 6. Fix the aluminium back studs.

While keeping the timber split jambs plumb, pack behind the aluminium back studs. Screw the aluminium back stud including the packing to the jack stud through the pre-punched holes.

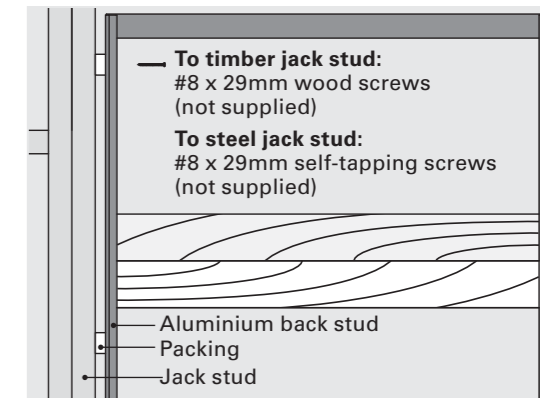

#### 7. Level the tracks.

The tracks must be fitted level and straight.

Screw the tracks to the lintel as shown using two screws (one in each side) for each track (four screws in total).

**Do not fix through the centre of the track.**

Screws should be fitted 50mm back from where the tracks join and 30mm either side of the centre of the track.

Wind screws in, only enough to level and straighten both tracks.

**Timber lintel:** #8 screws to penetrate lintel by at least 25mm (not supplied)

**Light steel lintel (under 2mm):** #8 self-tapping screws to penetrate lintel by at least 5mm (not supplied)

**Heavy steel lintel:** M5 machine screws (not supplied)

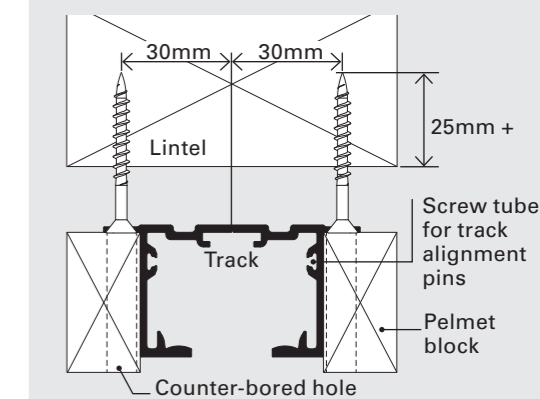

#### 8. Fix the bottom plate assemblies.

The doors must slide parallel with the bottom plate assembly. If not, gently tap the front of the bottom plates to the left or right until they do.

The doors should now slide smoothly and butt neatly together when closed.

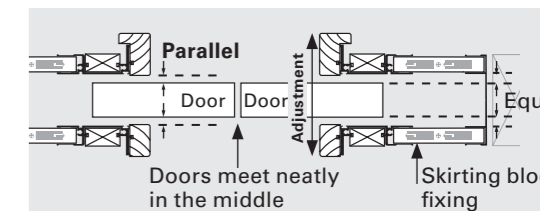

Go to page **2**

8. Fix the bottom plate assemblies to the floor:

To **concrete** floors:  
Use ø8mm x 90mm masonry anchors through the pre-drilled holes in the skirting fixing blocks of the bottom plate. (See the red stamped arrow on the timber).

To **timber** floors: Use ø3.15mm x 75mm nails on either side in the centre of the skirting fixing block thickness. (See the red stamped ⊕ on the timber). Pre-drill ø3mm holes for these nails.

**Concrete floor:** ø8 x 90mm masonry anchor  
**Timber floor:** ø3.15 x 75mm nail (not supplied)

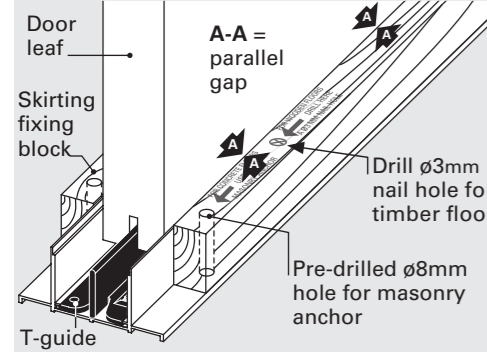

**9. Adjust the doors.**

Use the small end of the spanner supplied to adjust the doors for height and plumb.

Note: The top of the hanger pin screws into a self-locking Nyloc type nut in the carriage. For the assembly to remain in its adjusted position over time the hanger pin must be screwed into the nylon locking portion of the nut by at least 3 full turns. (The thread gets harder to turn once it reaches the start of the nylon locking ring).

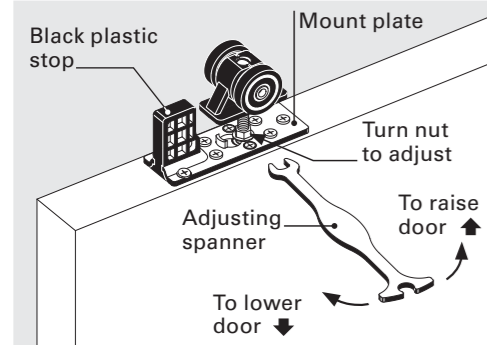

**Take care not to wind the hanger pin up too far on SofStop carriages as it will hit the activator in the track.**

**10. Adjust the track stops.**

The black plastic stop fitted to the mount plate is what contacts the track stop.

Using a 4mm Allen key, loosen the track stops and push them towards the cavity pockets.

Gently slide each door towards the centre closed position (where the tracks meet) and then open again.

Lock the track stops in place and test that the doors finish where you need them to stop.

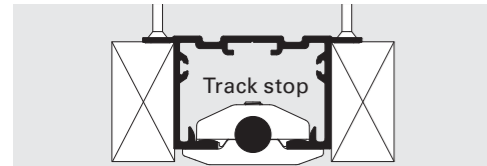

**SofStop® Single & Twin**

(Repeat steps for each door)

**Note: Single Soft Close** requires one front activator only.

**Twin Soft Open & Close** requires two activators for each cavity unit. The rear activators should already be in each track above the pockets (Step 4).

**11. Set front activator position.**

- a) Open one door and insert the front activator into the track. Slide it to about half way between the track joining point and the split jamb. Tighten 2 grub screws.

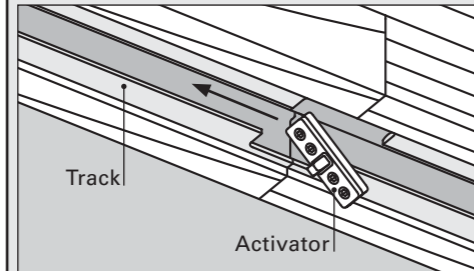

- b) Gently close the door until the pickup mechanism goes past the activator. You will hear a click.

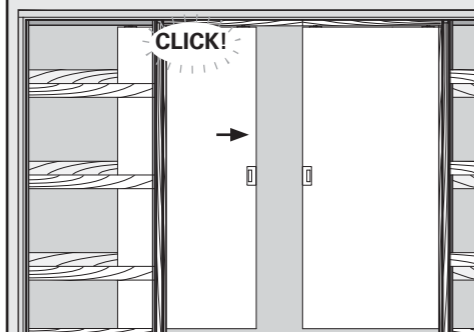

- c) Open the door again and loosen the activator grub screws. The cassette is now charged.

- d) Hold the distance setting tool against the other closed door. Gently close the door.

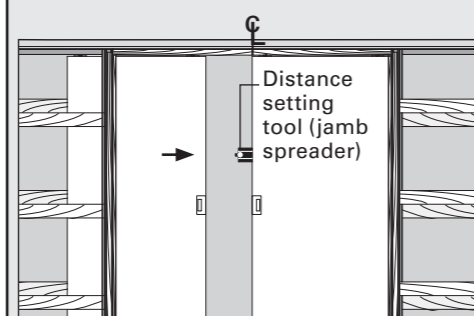

The activator will slide along the track into the correct position.

- e) Without moving the activator, open the door and securely tighten all four grub screws

- f) Repeat for the second door.

**WARNING:** If the door soft closes, but does not come to a stand still on the track stop, you risk breaking the hook on the soft close mechanism. If you use the distance setting tool correctly this will be avoided.

**SofStop® Twin ONLY**

**12. Set rear activator position.**

- a) Close the door and move the rear activator into the approximate centre of the pocket. **Do not tighten grub screws.**
- b) Position the distance setting tool inside the back stud and gently open the door onto it. The activator will slide along the track into the correct position. The rear activator is now positioned. Securely tighten all four grub screws.
- c) Repeat for the second door.

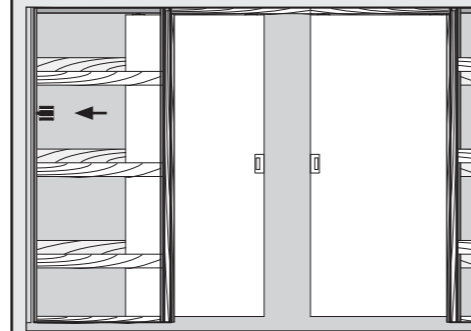

**Note: Twin SofStop cannot be adjusted after installation of wall linings.**

**13. Fit the head jambs.**

Before fitting head jambs, adjust the door for plumb and for the desired clearance under the door (Step 9).

Slide the head jamb into place between the vertical jambs.

Flush up the joints, then screw into place.

Gently tap wooden plugs to cover the screw heads.

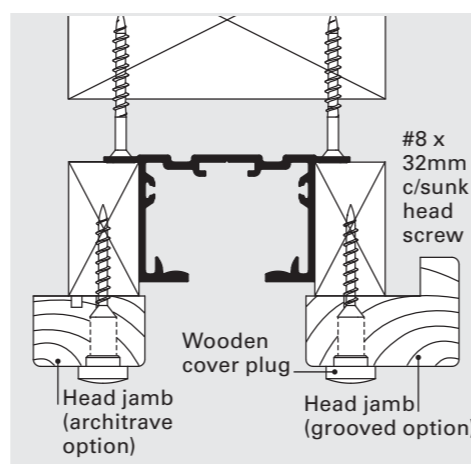

After installation but before lining, clean the full length of the inside running surface of the track with a soft rag.

**TAPE UP THE TRACK** to ensure no dust or debris enter the track or SofStop mechanism during building works. Warranty does not cover damage arising from paint or debris in the track, wheels or mechanism.

**Finishing**

**14. Fixing the wall linings.**

**NB: If installing Twin SofStop DO NOT line the pocket until the SofStop mechanism has been installed and tested.**

The cavity slider comes with split jambs intentionally 'rounded out' to accommodate any slight bowing of the door leaf and to allow door hardware to clear the jambs.

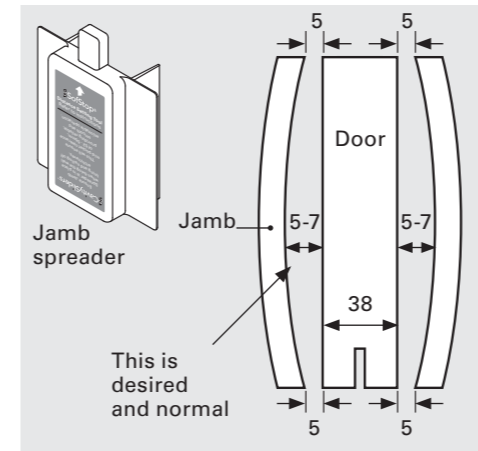

The standard clearance is 5-7mm between door and split jamb using a 38mm door.

The supplied 'jamb spreader' should be inserted into the cavity slider opening prior to fixing wall linings and architraves.

Wherever possible, linings should only be glued on. Use short drywall screws to hold linings in place until glue is dry.

For 10mm linings use **maximum 25mm** long drywall screws.

Sealing the inside of plasterboard linings and MDF architraves is recommended.

**15. Fitting architraves.**

Nail the architraves to the four vertical jambs and the two horizontal head jambs.

Use panel pins with a maximum length of 25mm plus the thickness of the architrave.

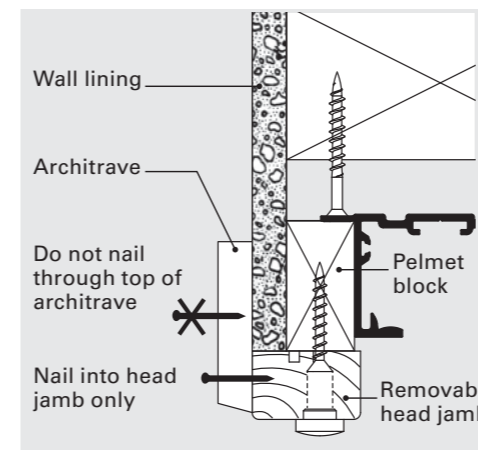

Nail the back of the architrave to the split jamb blocks using panel pins with a maximum length of the combined thickness of the architrave and wall linings plus 15mm.

**15. Note (To ensure head jambs are removable):** Nail the horizontal architraves to the head jambs; however **do not** nail them to the timber pelmet blocks above the head jamb.

**16. Fitting skirting.**

Make sure that you do not puncture the aluminium extrusion of the bottom plate assembly.

Use panel pins to fix the skirting to the fixing block.

**Do not hammer too hard against the bottom plate. This may damage the channel where the door slides.**

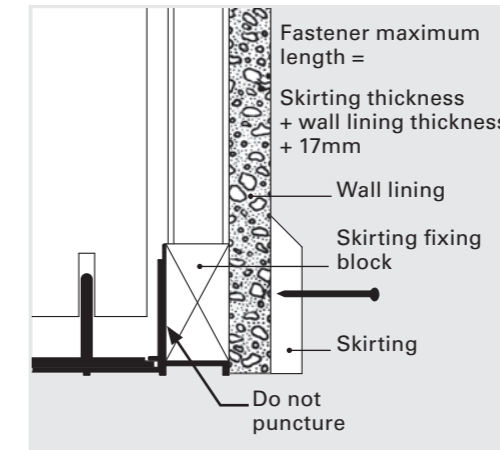

**17. Insert the track notch cover if required.**

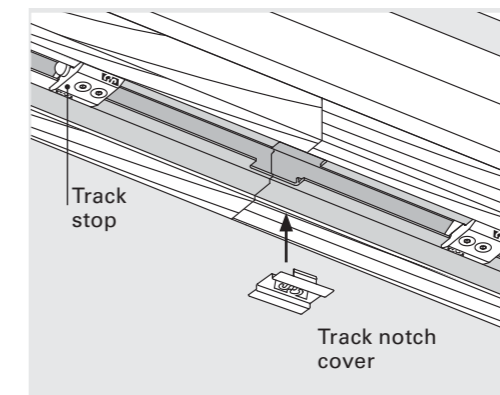

**18. If you need to remove doors:**

Begin by removing the architrave and head jamb from one side (if fitted).

Make a thin knife cut where any paint joins two components so as not to tear existing paint work.

Fit the club end of the adjusting spanner over the hexagonal nut at the bottom of the hanger pin.

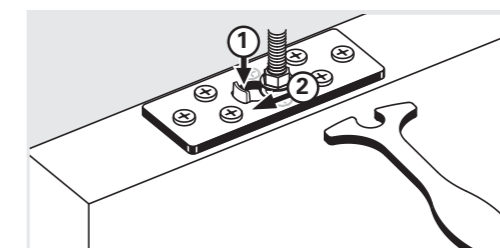

Use the extended part of the spanner to press down the plunger pin that protrudes up from the mounting plate.

Once this plunger is fully depressed, slide the spanner sideways towards the plunger pin.

18. The whole carriage (including the hanger pin) will now disengage from the mounting plate.

It is not always easy to slide the spanner sideways. You may need to relieve the door's weight by putting a wedge between door and floor.

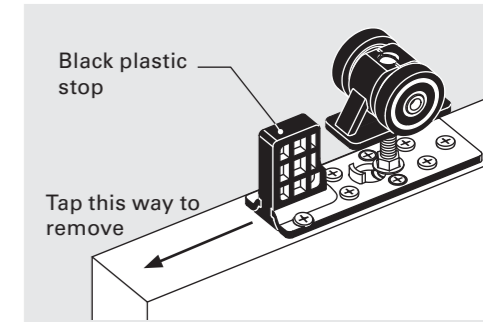

Do the same with the other carriages.

Finally, remove the black plastic stop that is tightly fitted into the mounting plate at the front of each door leaf.

Remove this by tapping it out in the direction shown using a hammer and drift.

Slide the carriages towards the centre of the opening to remove.

Use a 4mm Allen key to remove the track stops fitted in the middle where the doors meet.

**CS Cavity Sliders Auckland Head Office**  
5 - 7 Rakino Way, Mt Wellington 1060

T +64 9 276 0800  
E info@csfordoors.co.nz  
W www.cavitysliders.co.nz



**CS Cavity Sliders Australia**  
1/7-11 Rodborough Rd,  
Allambie Heights, NSW 2100

T 02 9905 0588  
E info@cavitysliders.com.au  
W www.cavitysliders.com.au



© Cavity Sliders Limited. All copyright and other property in this document is reserved by Cavity Sliders Limited. Details and specifications are subject to change without notice. Whilst all care is taken to ensure the accuracy of all information, no responsibility will be accepted for any errors or omissions. Drawings are not to scale. \*Guarantee conditions apply. Contact Cavity Sliders for details.  
**CS CAVITY SLIDERS®** (O.D. 1986).  
NZ Patent No: 533838. Aust. Patent: 2005 202818.